



# Gestão de Projectos de Desporto

Posicionamento e Ferramentas



*Não existe nada mais prático  
do que uma boa teoria.*

**Kurt Lewin**



# Parte I

## “Dialectos”

“Desculpe, mas...  
está mesmo a falar de quê?!”

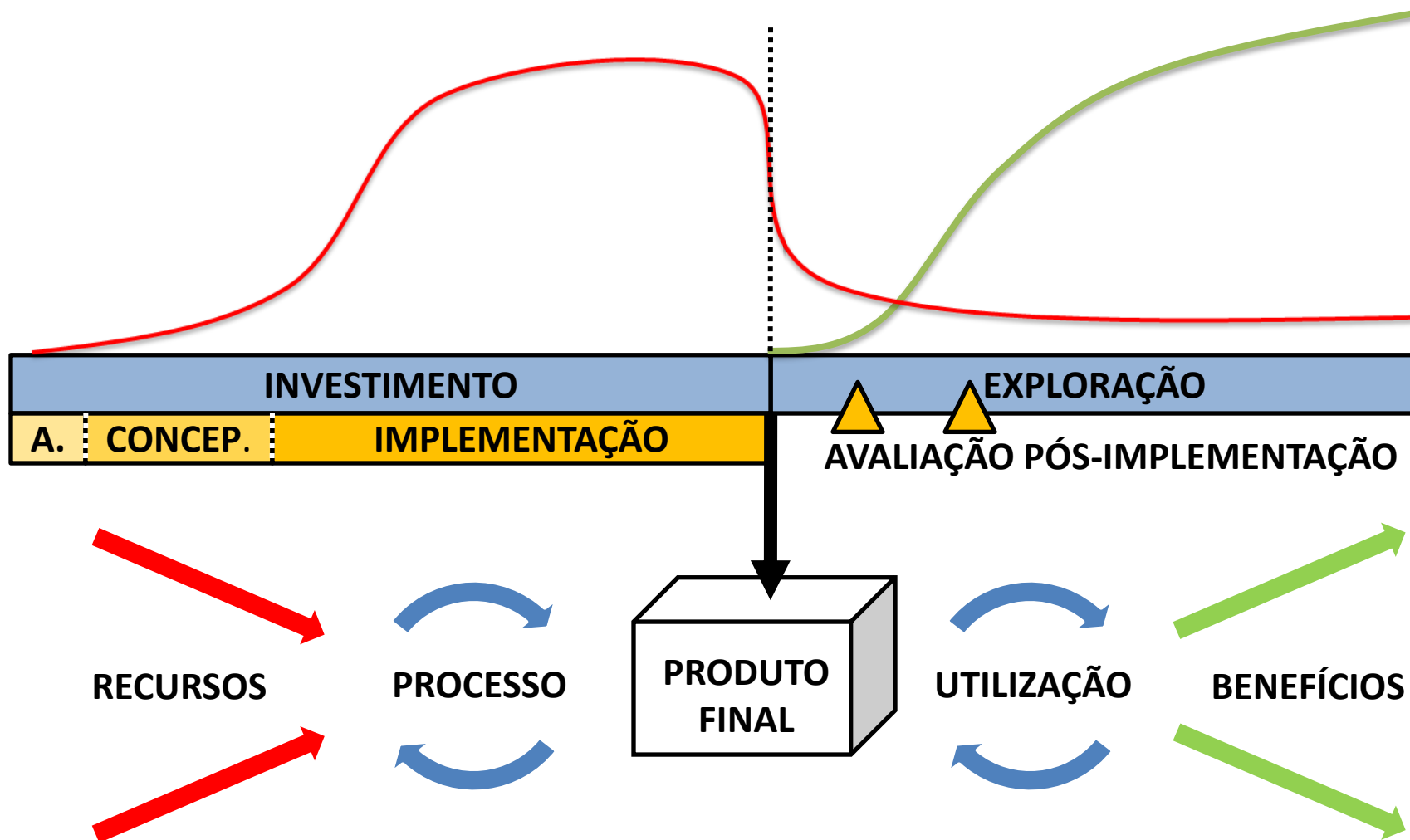

# “Desculpe, mas... disse utilização?”

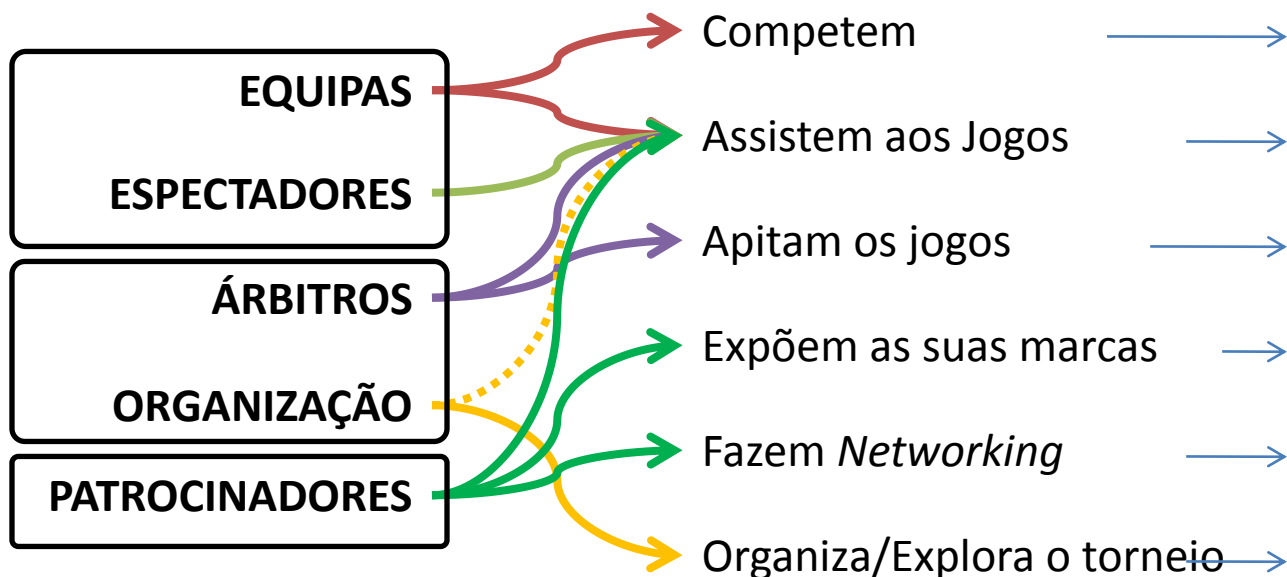



# **Parte II**

## **Projectos Valiosos**



*“Esta iniciativa, tem como objetivos:*

- Rentabilizar os espaços desportivos*
- Sensibilizar as respectivas freguesias para a conservação e manutenção dos mesmos*
- Promover a prática desportiva.”*



Afinal, queremos trabalhar  
para trabalhar ou para  
**gerar valor**





De Intenções para Resultados:

# Valor p/ Entidade Promotora

GINÁSIO

Valor p/  
Promotor

Evitar Custos

Contribuir p/ outros  
Objectivos da organização

Melhorar o Serviço

Melhorar a qualidade do  
serviço no segmento do  
controlo de peso

Aumentar os Proveitos

# De Intenções para Resultados:

# Valor p/ Cliente

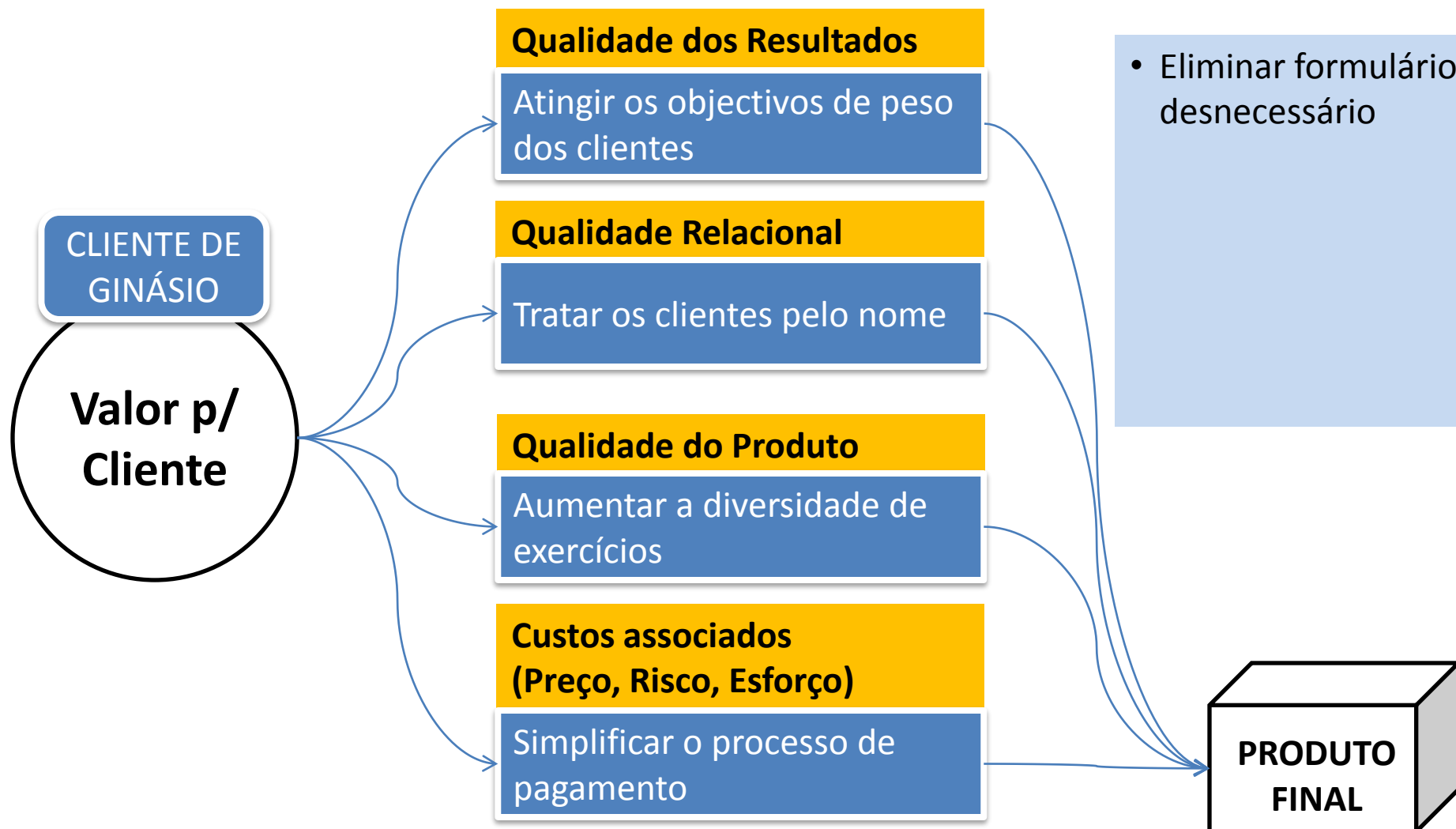

# De Intenções para Resultados: Valor p/ Entidade Promotora

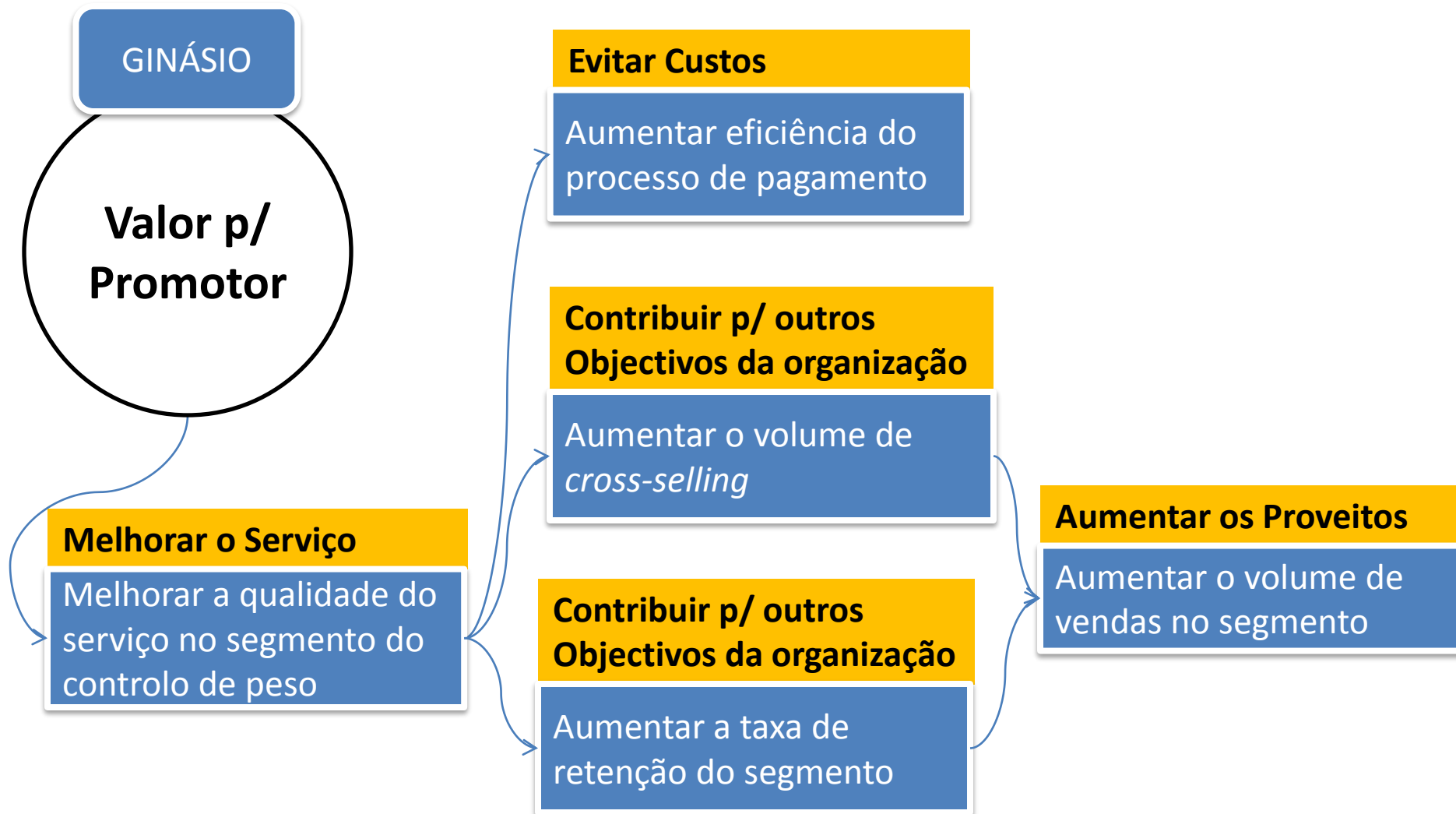

De Intenções para Resultados:



# Projectos Valiosos

*“Esta iniciativa, tem como objectivos:*

- *Rentabilizar os espaços desportivos*
- *Sensibilizar as respectivas freguesias para a conservação e manutenção dos mesmos*
- *Promover a prática desportiva.”*

# De Intenções para Resultados: Projectos Valiosos

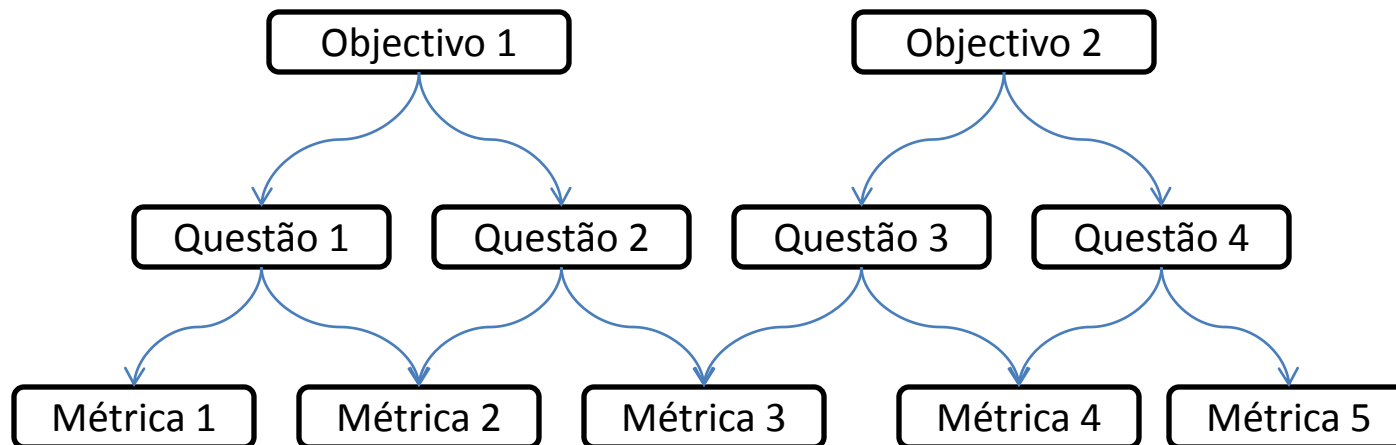

# De Intenções para Resultados: **Projectos Valiosos**



Objectivo	Intenção:
	Enfoque:
	Alvo:

# De Intenções para Resultados: Projectos Valiosos

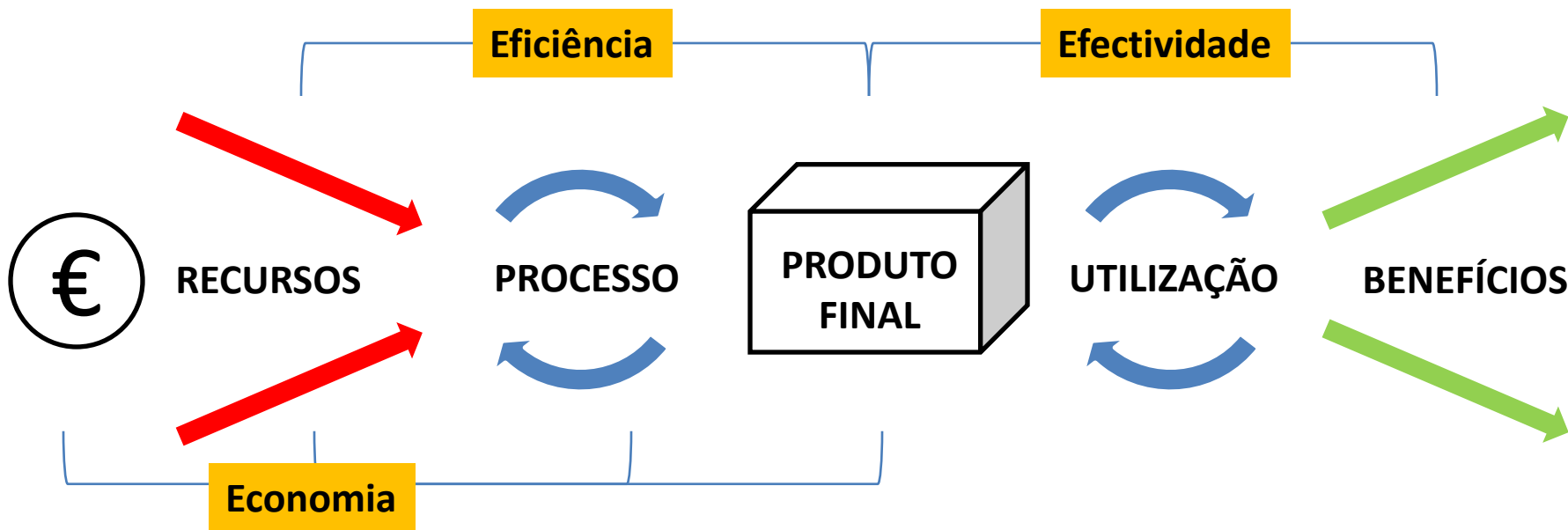

# De Intenções para Resultados: Projectos Valiosos



Dimensão	Métricas
Recurso	
Eficiência	
Produto Final	
Efectividade	
Benefícios	



# **Parte III**

## **Projectos Robustos**

# Porque é redonda a bola de Futebol?



**PRODUTO  
FINAL**

**JOGADORES**



# Porque é redonda a bola de Futebol?



**PRODUTO  
FINAL**

**ESPECTADORES**



# Porque é redonda a bola de Futebol?



**PRODUTO  
FINAL**

**TV**



# Porque é redonda a bola de Futebol?



**PRODUTO  
FINAL**

**ÁRBITROS**





# Parte IV

## Projectos Aprendentes

# Temos de reinventar a roda?

(12) INNOVATION PATENT  
(19) AUSTRALIAN PATENT OFFICE

(11) Application No. AU 2001100012 A4

(54) Title  
Circular transportation facilitation device

**Mecanismo Circular de Facilitação dos Transportes,  
Ou seja, Mr. John patenteou A RODA!**

(51) International Patent Classification(s)  
B60B 001/00

(21) Application No: 2001100012

(22) Date of Filing: 2001.05.24

(45) Publication Date: 2001.08.02

(45) Publication Journal Date: 2001.08.02

(45) Granted Journal Date: 2001.08.02

(71) Applicant(s)  
John Keogh

(72) Inventor(s)  
Keogh, John Michael

(74) Agent / Attorney  
Sandercock & Cowie 69 Robinson Street Dandenong Victoria AU

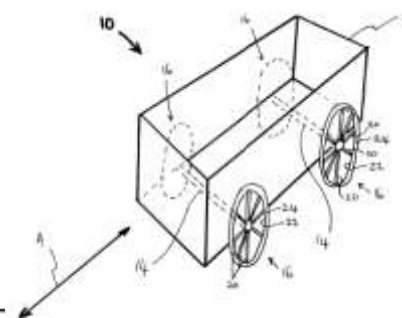

FIGURE 1

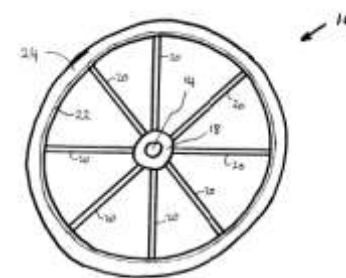
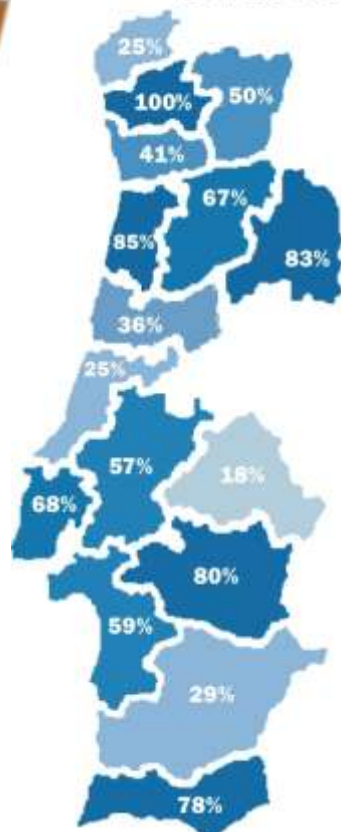

FIGURE 2

# Temos de acertar à primeira?

## Taxa de Execução

63%



- 69 Promotores Locais
- 16 fins-de-semana
- 136 sessões de formação
- 924 horas de formação
- 560 dirigentes
- 50 concelhos
- 23 formadores
- 63.120 Km percorridos



O sucesso desportivo prepara-se, a preparação aprende-se.

**Aprender bem para dirigir melhor**



# Da Experiência para o Conhecimento:

# Projectos Aprendentes

**Questionamento Sistemático**

Quem? O quê?  
Onde? Quando?  
Quanto? Porquê?  
Como?

Prospecção e  
Formação da  
Oportunidade



**Chuva de Ideias**

Geração de Ideias  
e Soluções

**Diagrama de Afinidades**



**Testes de Conceito**

Experimentação e  
Seleção de Ideias



**Storyboarding**





# **Diapositivos:**

<http://gpdesporto.blogspot.com>

**OBRIGADO!**